

Provided by the  
**Town Of East Granby  
Building Department**

# **A GUIDE TO SWIMMING POOLS**

## **ILLUSTRATIONS TO SECTION AG101**

The drawings contained in this brochure pertain to the  
2003 International Residential Code portion of the  
2005 State of CT Building Code.

They are for illustration purposes only and the written  
code text shall apply.

Location \_\_\_\_\_

Building Permit# \_\_\_\_\_

**TOWN OF EAST GRANBY: SWIMMING POOL REQUIREMENTS**

**The building permit application must be accompanied by the following:**

- I. Plot plan showing location of house, pool, fence and septic with distances to side & rear yards.
- 2. Approval from the Farmington Valley Health District if required — need separate form.
- 3. Plans of the structure stamped and sealed by an engineer — (In ground only)
- 4. Drawing of fencing & enclosures showing dimensions
- 5. Permit fee.
- 6. Per State Statute, clearance from the tax collector.

**Pool installation requirements. This list is not all inclusive; please refer to pool packet.**

- A 48” barrier will be provided to protect the pool access. Including a temporary fence for inground pools prior to filling.
- Access gates will be self closing and self latching (if less than 54” high they shall be on the pool side and be protected within 18” of release mechanism).
- Doors providing direct access to the pool shall either have an alarm, a self closing self latching device 54” above the floor, or a safety cover over the pool.
- No receptacles within 10’ of pool. (locking type receptacle for pool equipment must be at least 5’ from pool and GFCI protected).
- All metal parts of pool structure, fixed metal parts within 5’ of pool, pump motors etc., shall be bonded with a minimum #8 solid copper wire.
- Convenience GFCI receptacle shall be provided between 10’ and 20’ from pool.
- Trench depth for 20 amp. circuit to pool equipment shall be 12” minimum.
- A surface pool alarm shall be installed pursuant to Public Act 99-140.
- All swimming pool pumps must be equipped with a time clock.
- Heated pools require a pool cover unless over 20% of the heating energy is from non-depletable sources.

**REQUIRED SWIMMING POOL INSPECTIONS:**

The following is a list of inspections that need to be performed prior to the continuation of work. Requests for inspections can be made by calling the Building Department at 860-653-3444.

- **TRENCH AND BONDING:** Electrical trench depth verification and bonding of pool and metal appurtenances including metal reinforcing for gunite pools.
- **FINAL ELECTRICAL:** Location of equipment and GFCI protection. Convenience outlet provided.
- **FINAL:** Swimming pool access protection must be provided before pool can be used.

Each swimming pool installation requires a Building and an Electrical permit. Additional permits and inspections are required for pool decks.

**I have read and understand the requirements listed above.**

Applicant Signature \_\_\_\_\_ Date \_\_\_\_\_

HomeownerSignature \_\_\_\_\_ Date \_\_\_\_\_

Substitute House Bill No. 5070

**Public Act No. 99-140**

**An Act Concerning Alarms for New Swimming Pools.**

Be it enacted by the Senate and House of Representatives in General Assembly convened:

(NEW) (a) As used in this section, "pool alarm" means a device which emits a sound of at least fifty decibels when a person or an object weighing fifteen pounds or more enters the water in a swimming pool.

(b) No building permit shall be issued for the construction or substantial alteration of a swimming pool at a residence occupied by, or being built for, one or more families unless a pool alarm is installed with the swimming pool.

*Approved June 8, 1999. Effective October 1, 1999.*

# HEATH DEPARTMENT GUIDELINES

## REQUIRED SEPARATING DISTANCES

- Open Decks to any part of the Septic System .....5 feet
- Building without footing drain to Septic System ..... 15 feet
- Building with a full foundation and footing drain  
to Septic and Well .....25 feet
- Above ground pool to Septic System ..... 10 feet
- In-ground pool to Septic System and Well .....25 feet
- Pool filter water backwash and well.....75 feet

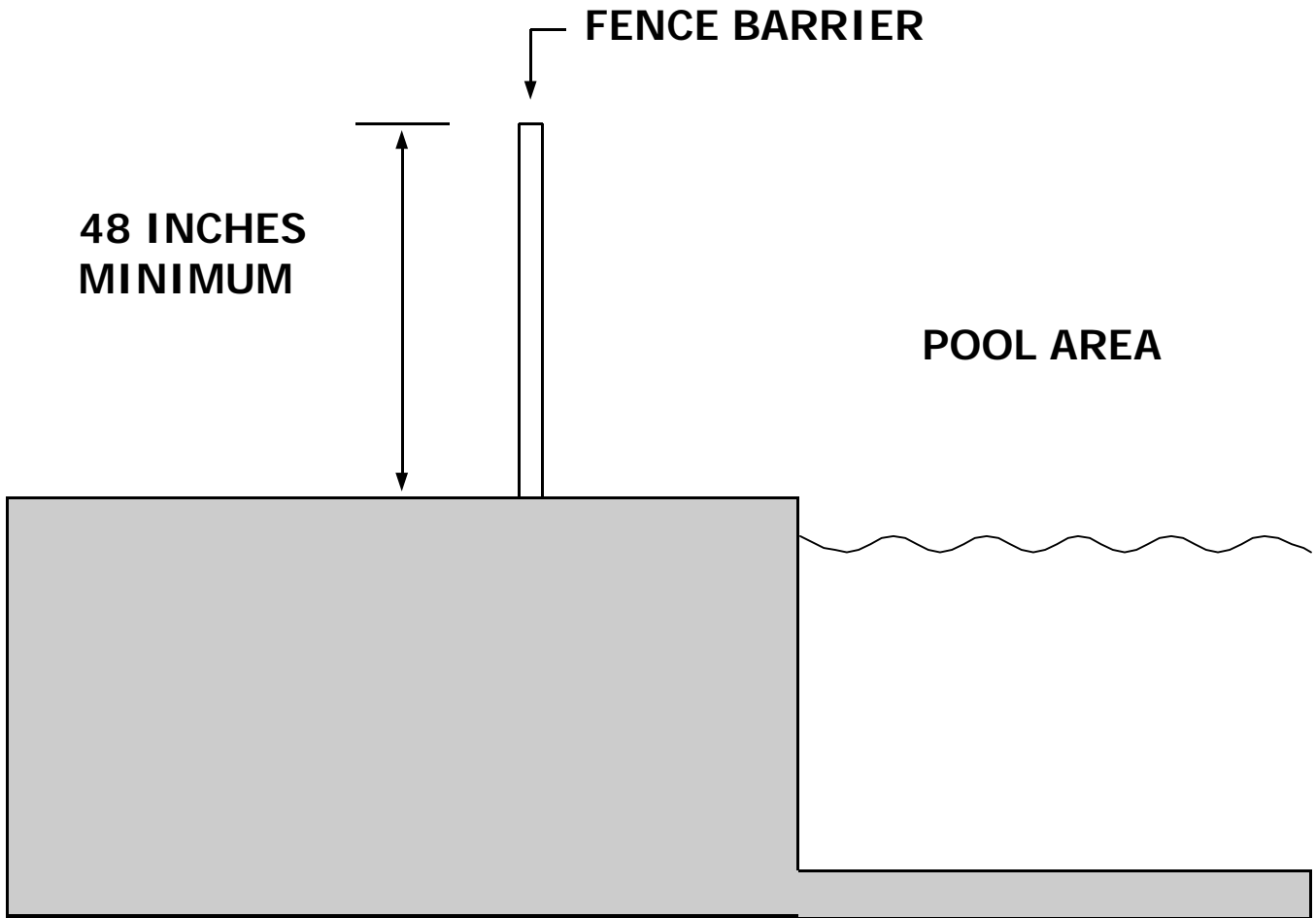

---

**CROSS SECTION**

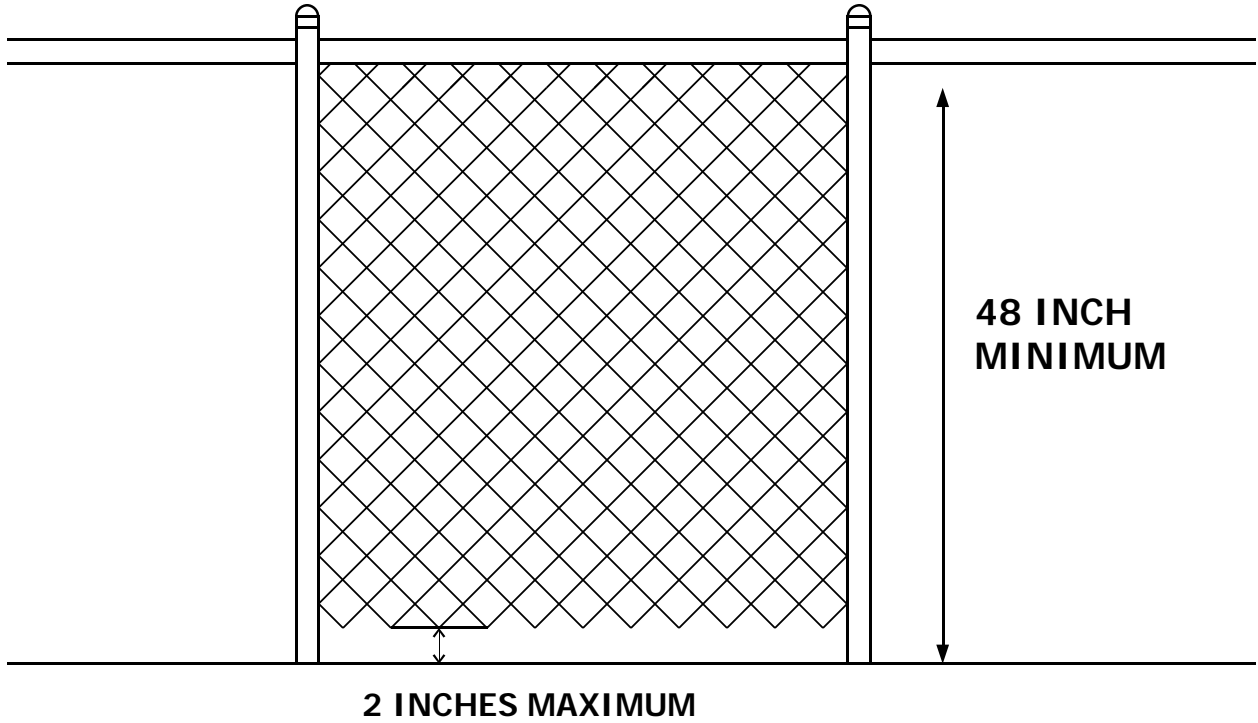

OUTSIDE OF THE POOL ENCLOSURE

---

**ELEVATION**

THE ABOVE GROUND SWIMMING POOL STRUCTURE  
COULD BE THE BARRIER IF:

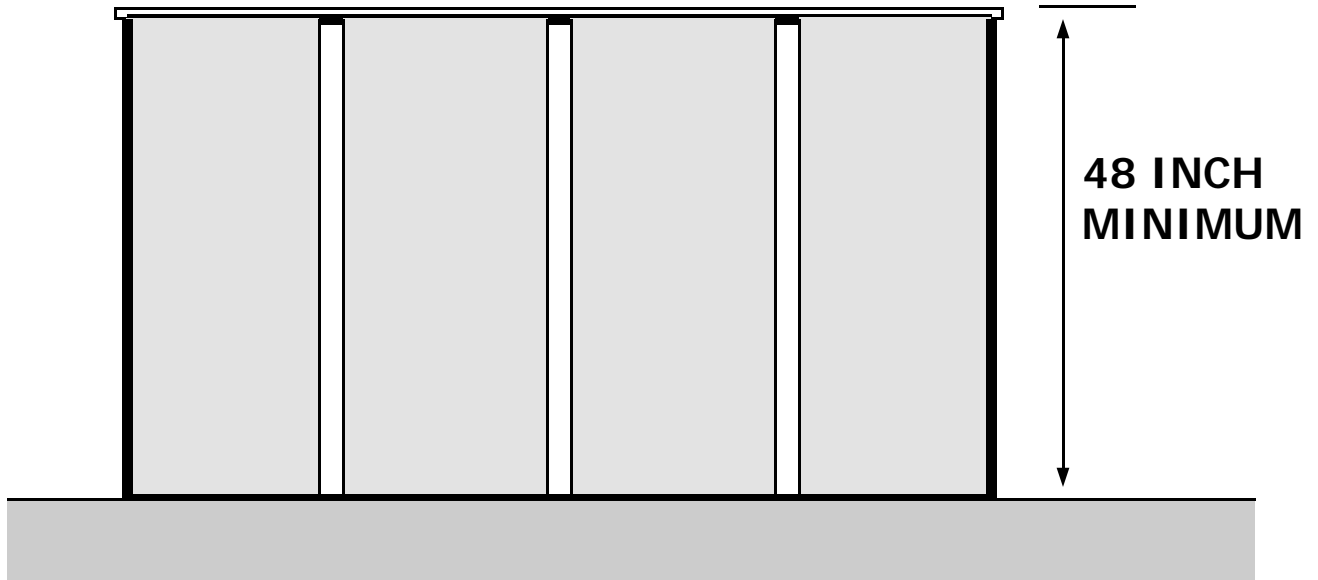

ABOVE GROUND POOL

---

**ELEVATION**

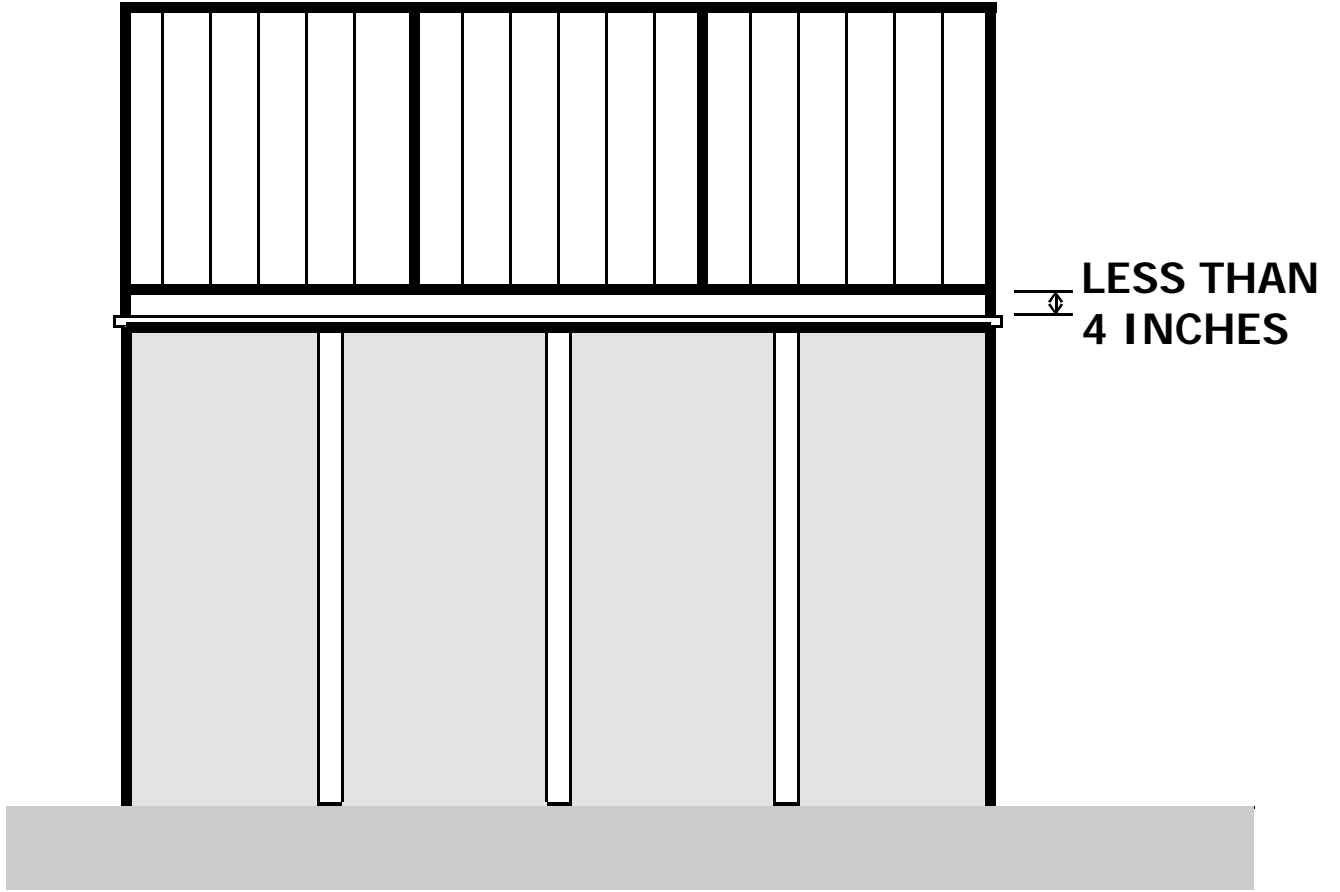

ABOVE GROUND POOL

---

ELEVATION



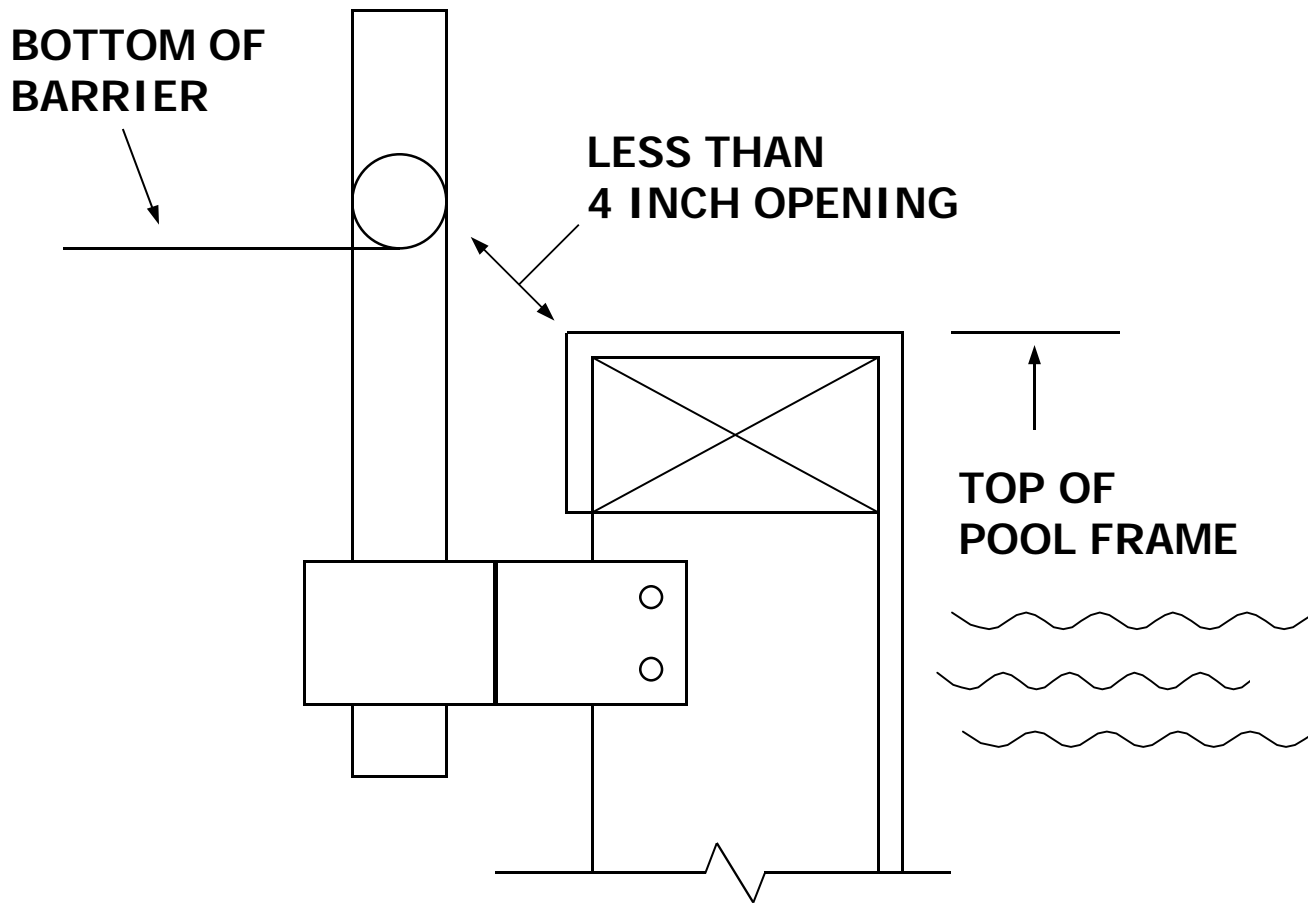

**BARRIER MOUNTED ON THE POOL STRUCTURE**

---

**CROSS SECTION**

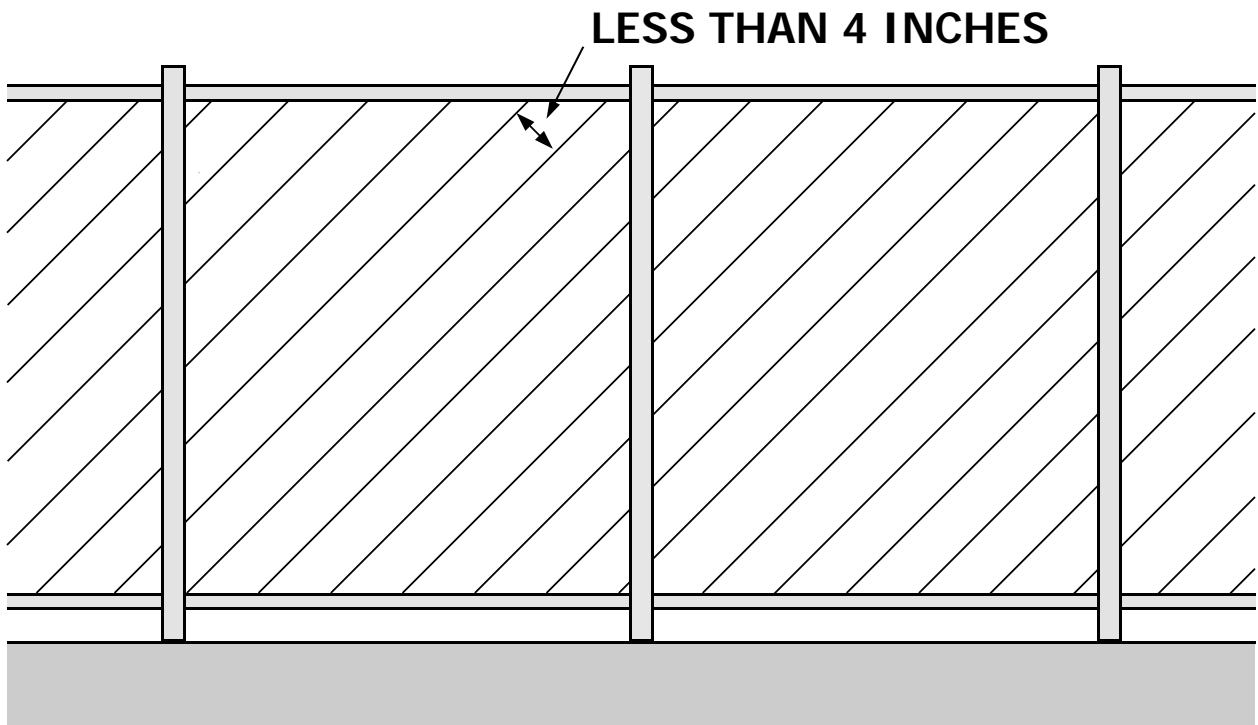
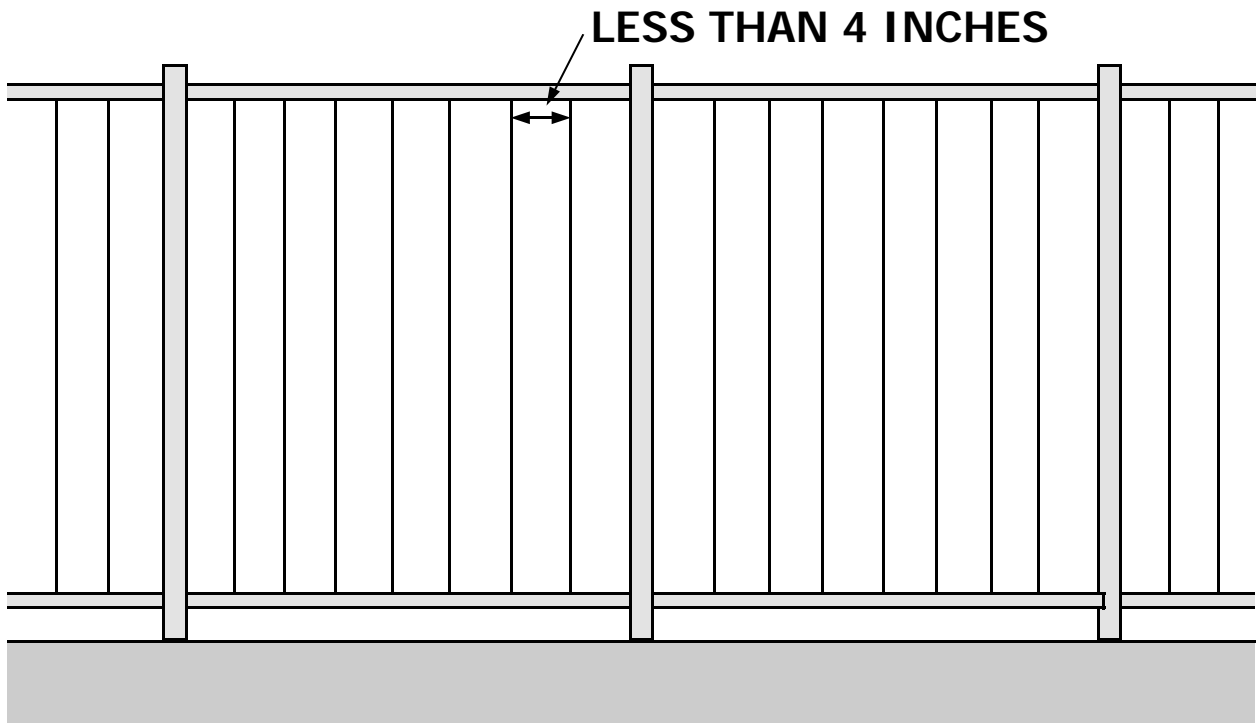

**SECTION 421.10.1, ITEM 2**

**ELEVATION**

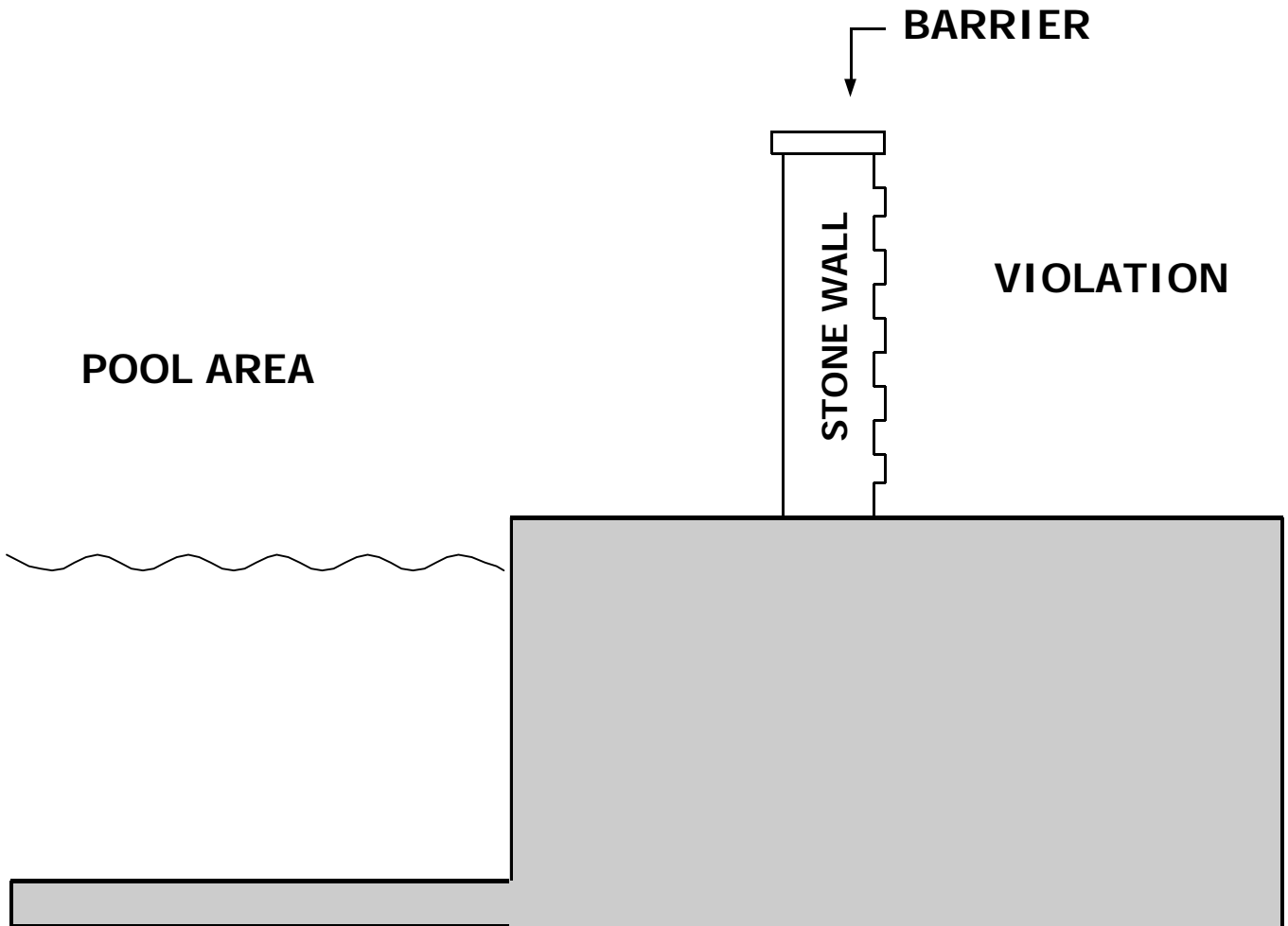

**SECTION 421.10.1, ITEM 3**

**CROSS SECTION**

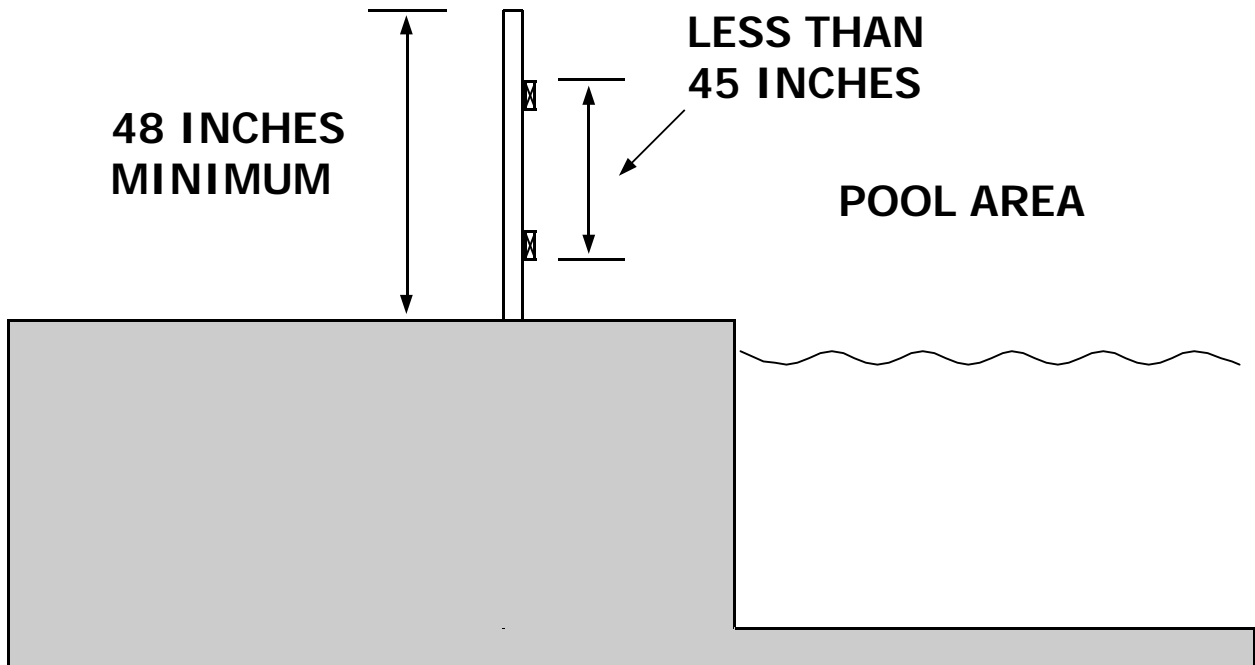

**CROSS SECTION**

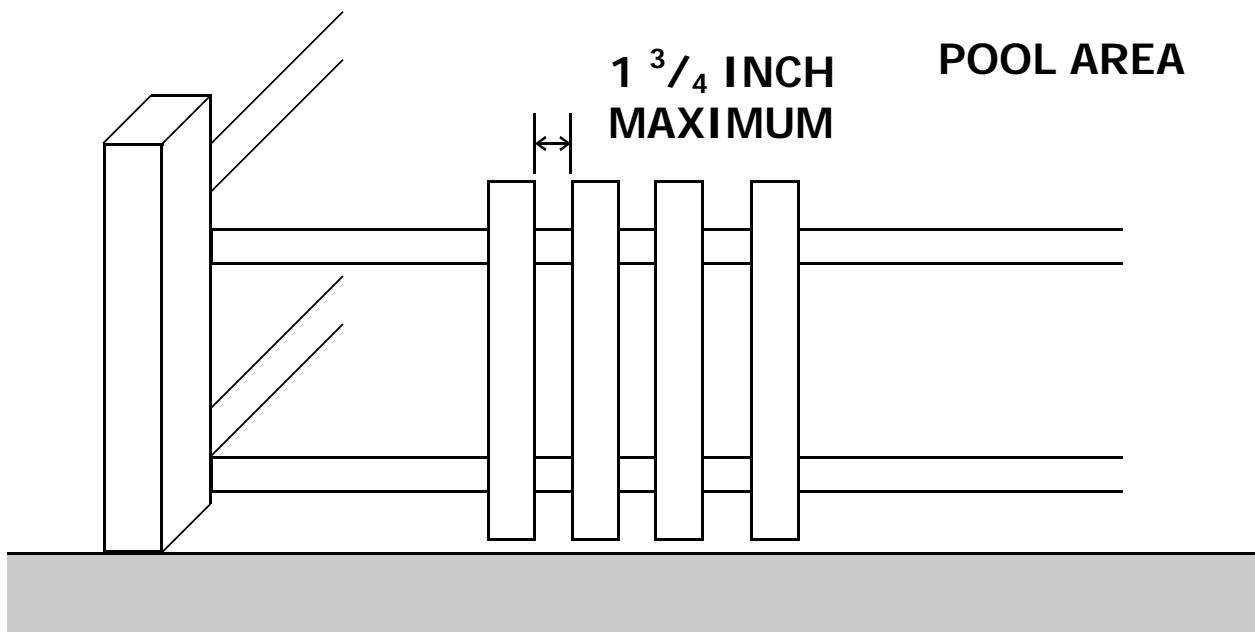

**SECTION 421.10.1, ITEM 4**

**ISOMETRIC**

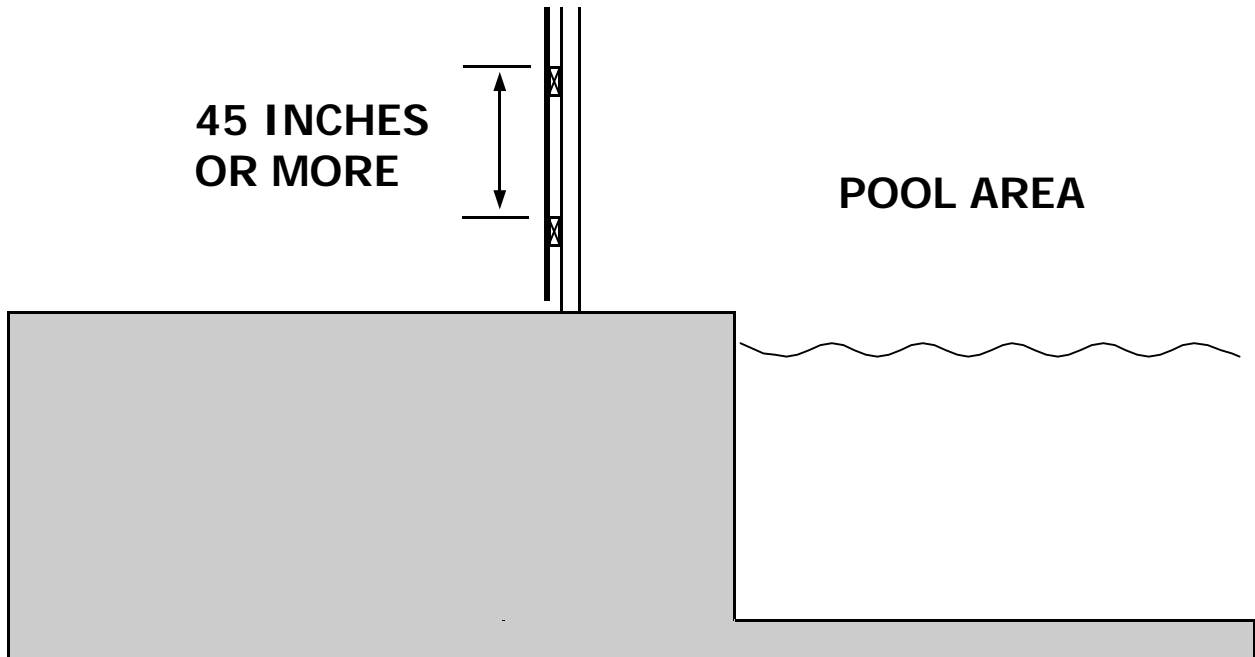

**CROSS SECTION**

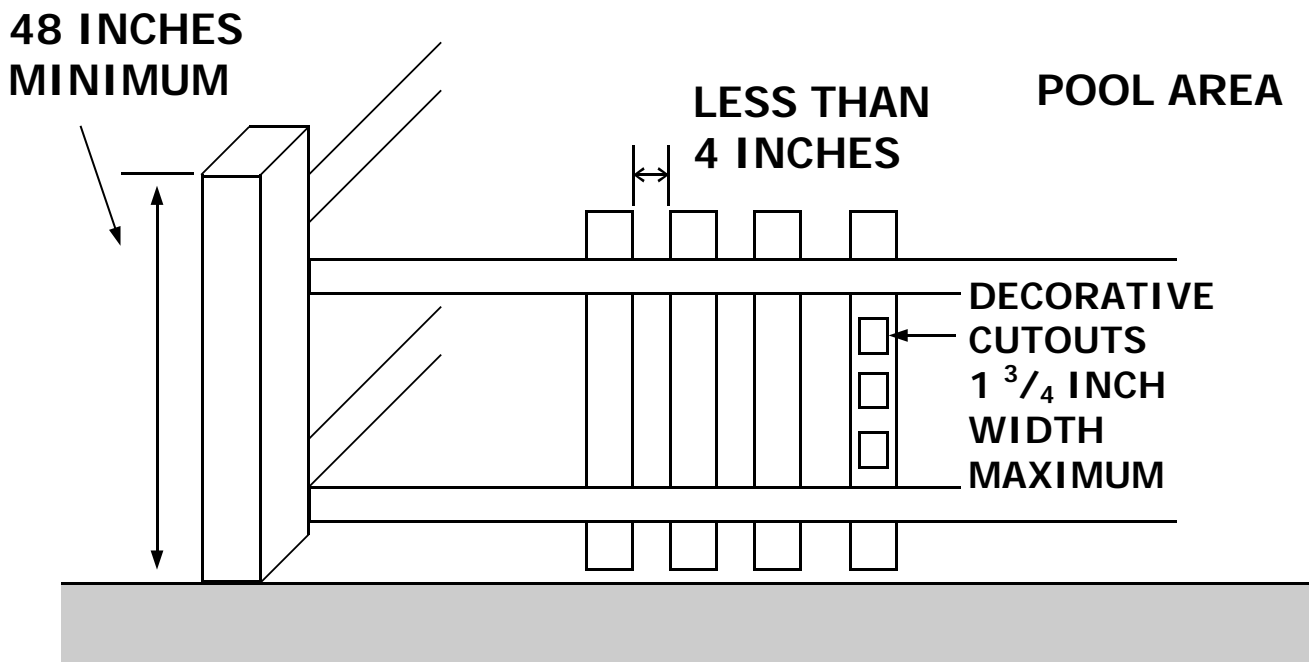

**SECTION 421.10.1, ITEM 5**

**ISOMETRIC**

1 1/4 INCH  
MAXIMUM  
MESH

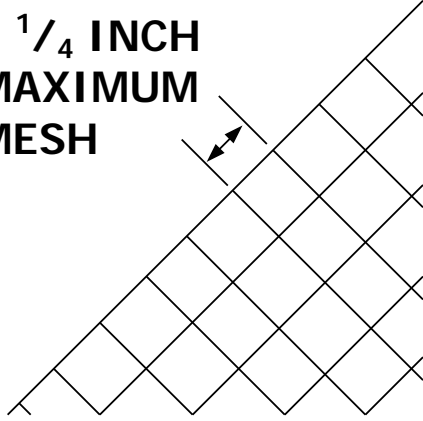

1 3/4 INCH  
MAXIMUM  
MESH WITH  
SLATS

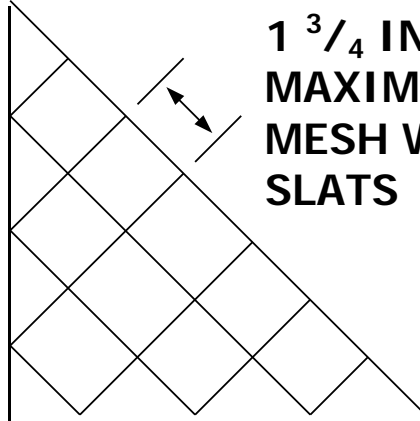

CHAIN LINK FENCE

SECTION 421.10.1, ITEM 6

ELEVATION

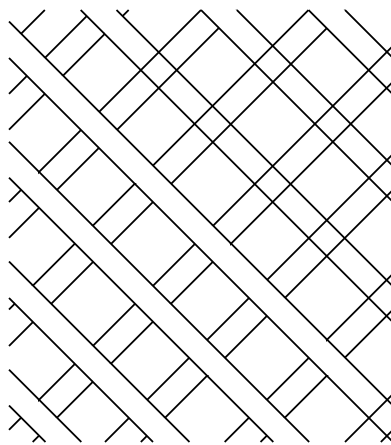

1 3/4 INCH  
MAXIMUM  
OPENING

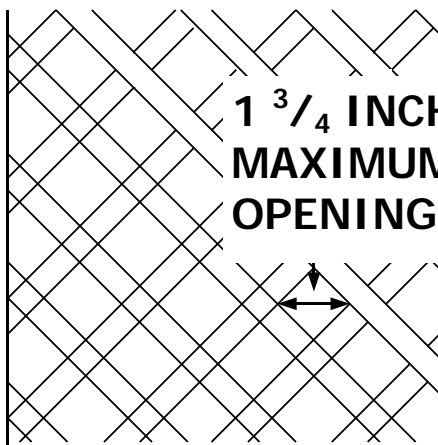

LATTICE FENCE

SECTION 421.10.1, ITEM 7

ELEVATION

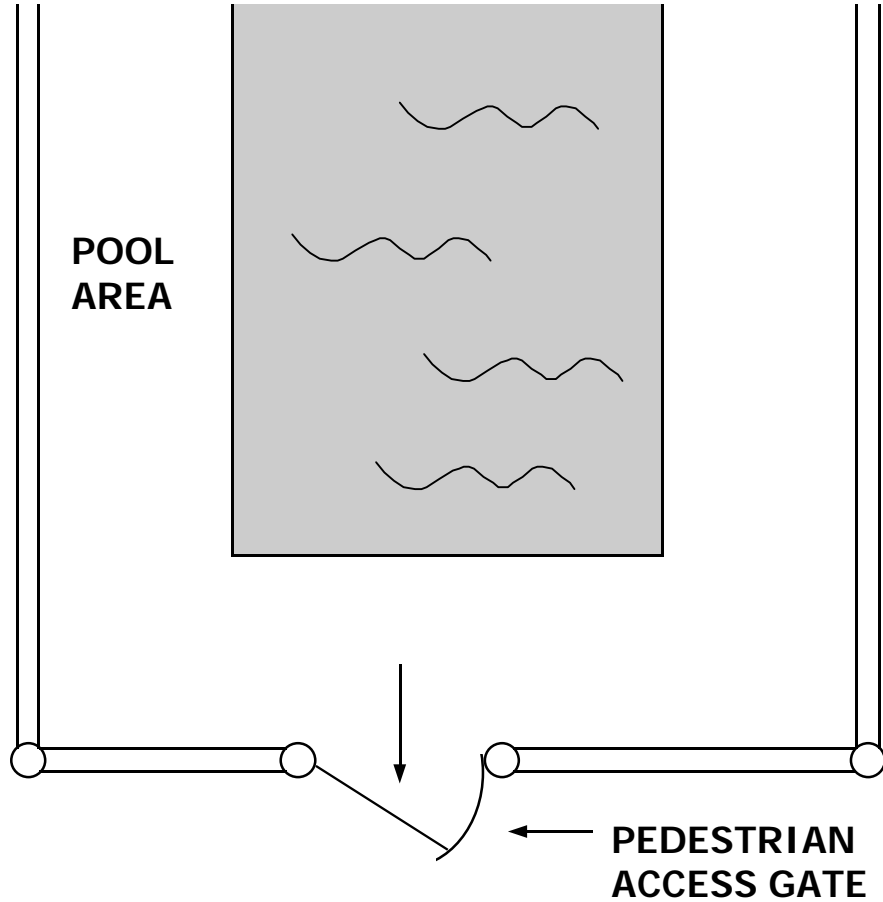

SHALL: COMPLY W/ ITEMS 1-7,  
EQUIPPED TO ACCOMMODATE A LOCKING DEVICE,  
OPEN OUTWARDS AWAY FROM POOL,  
SELF-CLOSING,  
SELF-LATCHING.

**SECTION 421.10.1, ITEM 8**

**SITE PLAN**

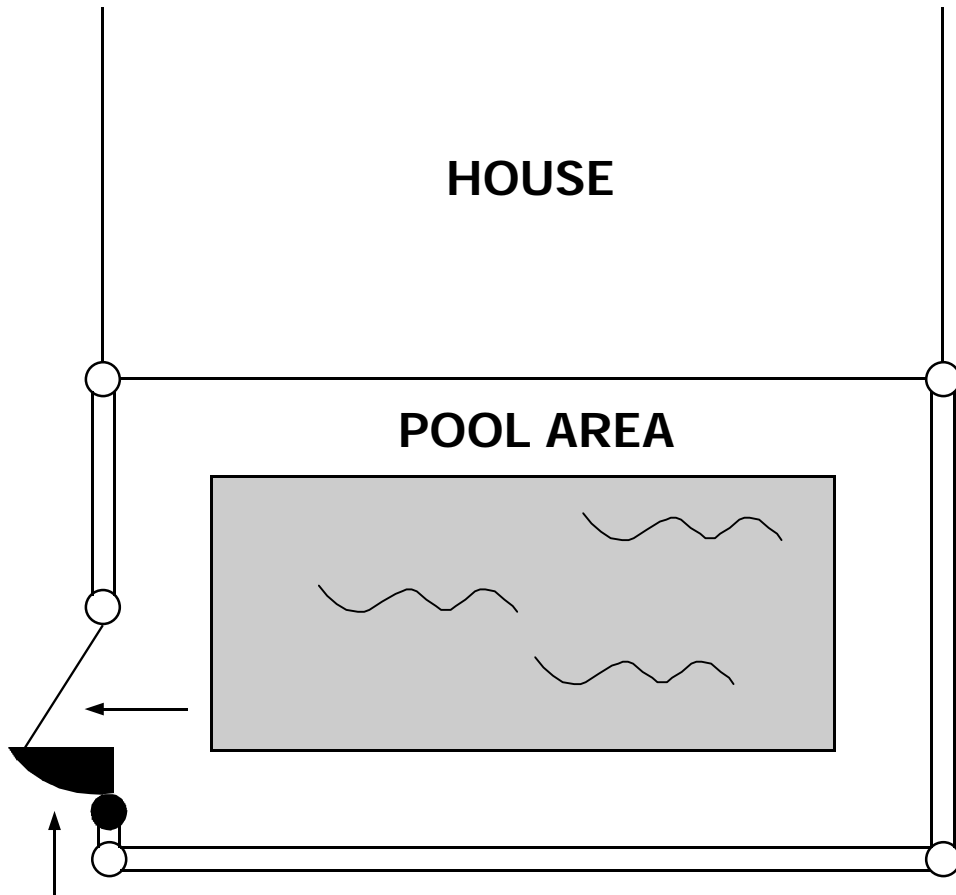

**ACCESS GATE OTHER  
THAN PEDESTRIAN  
ACCESS GATE**

SHALL: COMPLY W/ ITEMS 1-7,  
EQUIPPED TO ACCOMMODATE A LOCKING DEVICE,  
OPEN OUTWARDS AWAY FROM POOL,  
SELF-CLOSING,  
SELF-LATCHING.

**SECTION 421.10.1, ITEM 8**

**SITE PLAN**



**ACCESS GATE OR PEDESTRIAN ACCESS GATE**

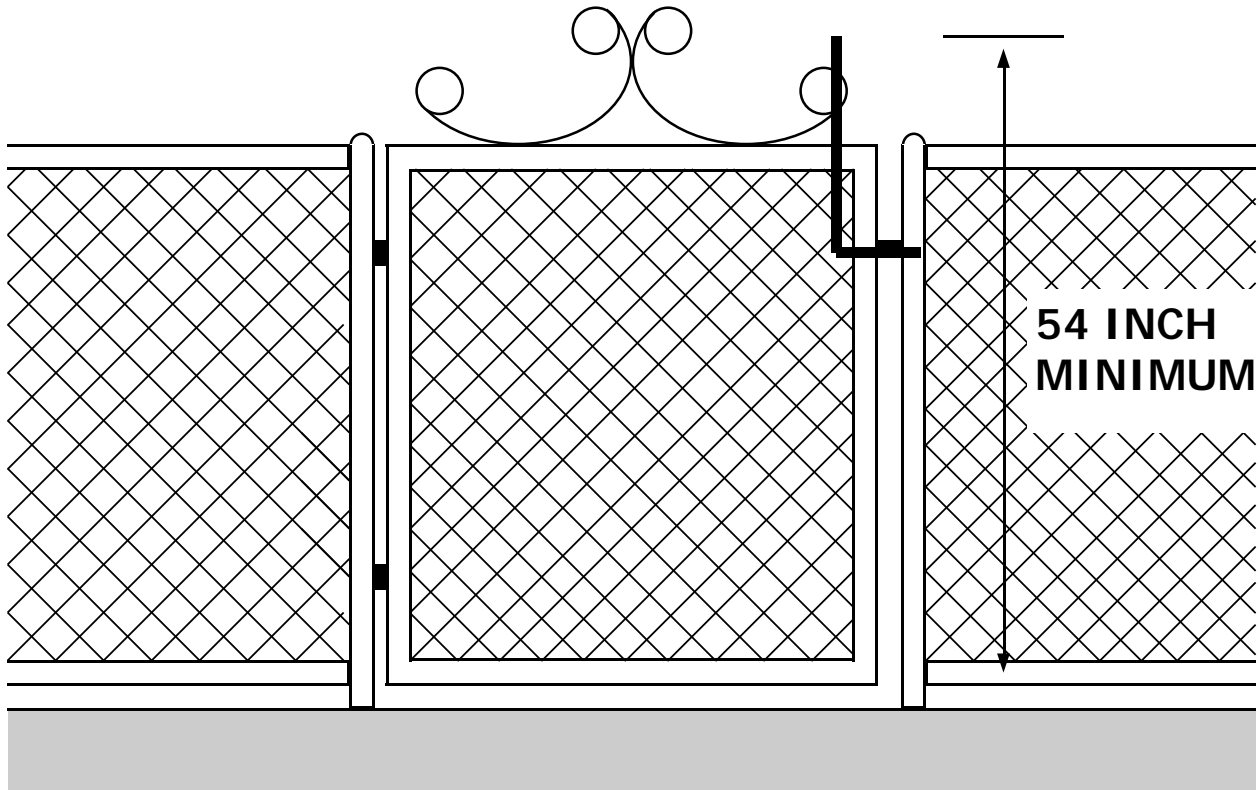

**INSIDE OR OUTSIDE POOL AREA**

**SECTION 421.10.1, ITEM 8**

**ELEVATION**

## ACCESS GATE OR PEDESTRIAN ACCESS GATE

$\frac{1}{2}$  INCH MAXIMUM  
OPENING WITHIN  
18 INCHES OF THE  
RELEASE  
MECHANISM

3 INCH MINIMUM  
BELOW TOP OF GATE

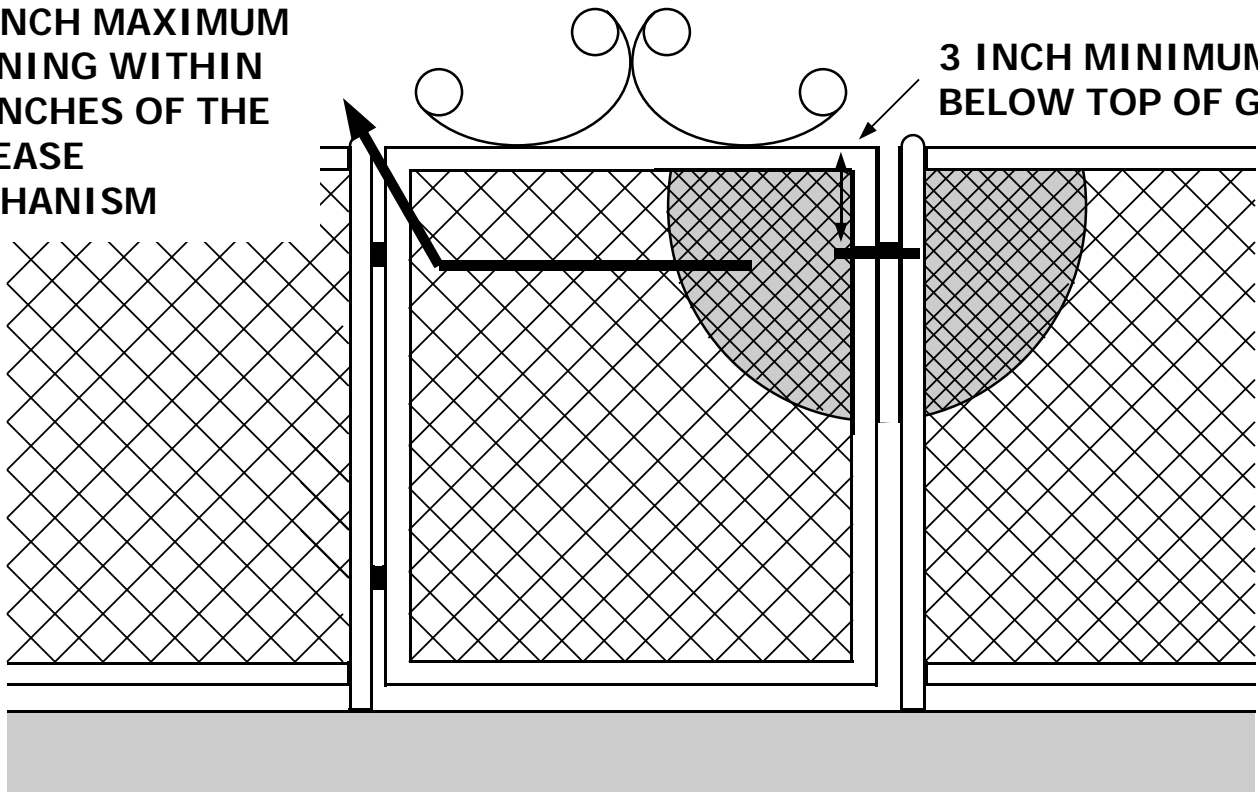

INSIDE POOL AREA ONLY

SECTION 421.10.1, ITEM 8a and 8b

ELEVATION

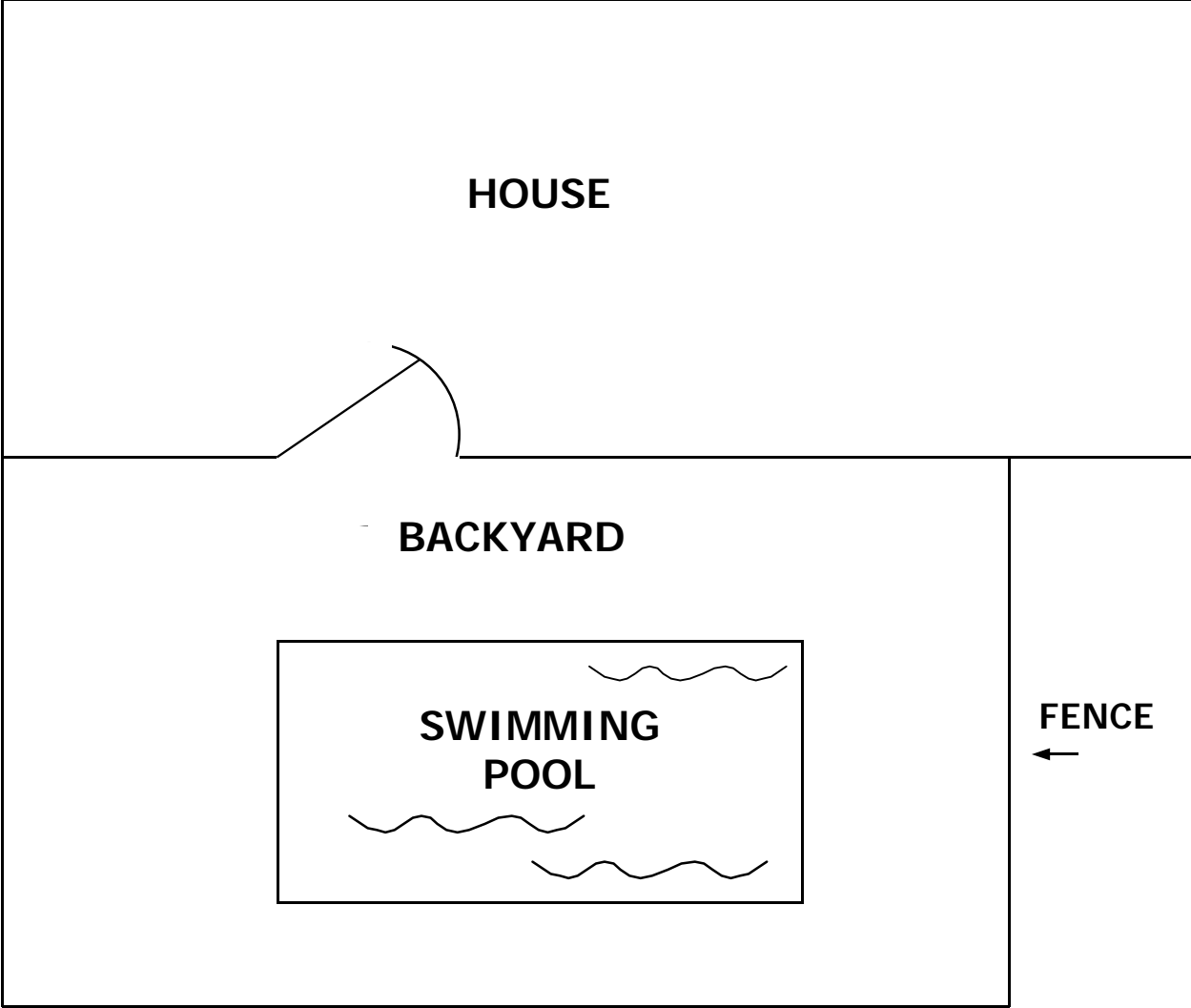

**SECTION 421.10.1, ITEM 9**

**SITE PLAN**

**OPTION 1 OF 3**

**ALARM  
DEACTIVATION  
SWITCH OR  
TOUCHPAD**

**54 INCH  
MINIMUM**

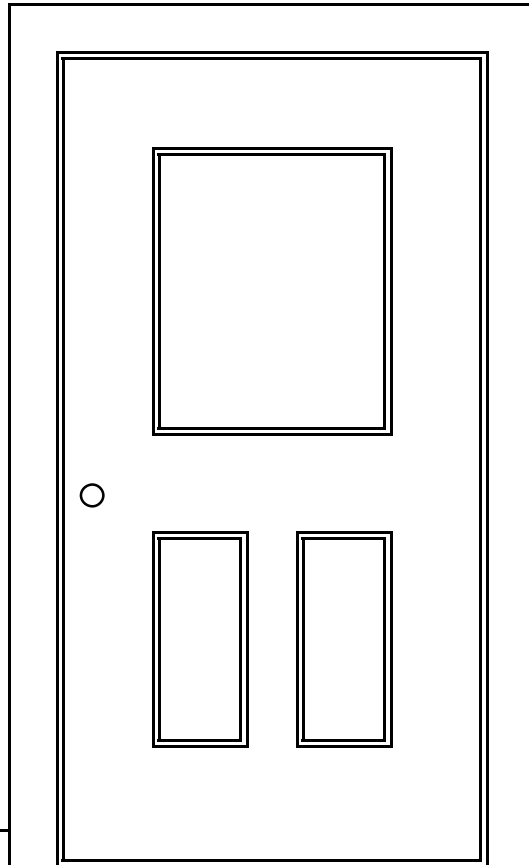

**SECTION 421.10.1, ITEM 9.1**

**ELEVATION**

## **THE DOOR ALARM SHALL:**

- Produce an audible warning when the door and its screen are opened.
- Audible warning sounds within 7 seconds of opening the door and
- Sound continuously for 30 seconds minimum.
- Have a minimum sound pressure rating of 85 dba at 10 feet.
- Be distinctive from other household sounds.
- Automatically reset under all conditions.
- Be equipped with manual means to temporarily deactivate the alarm for a single opening from either direction.
- Allow deactivation to last not more than 15 seconds.
- Have deactivation touch pads/switches located a minimum of 54 inches above the door threshold.

## **SECTION 421.10.1, ITEM 9.1**

**OPTION 2 OF 3**

- SELF-CLOSING AND SELF-LATCHING DEVICE
- SWING AWAY FROM POOL

**54 INCH  
MINIMUM**

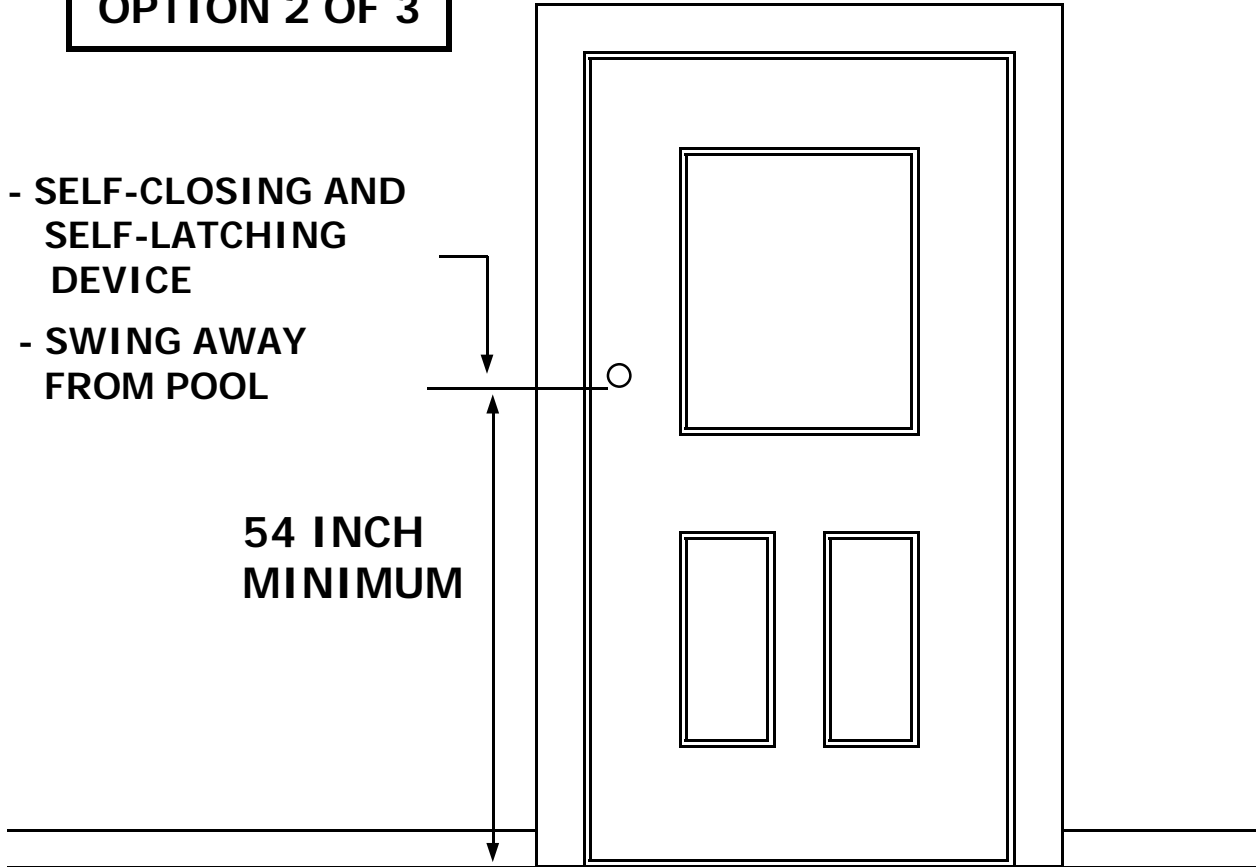

**SECTION 421.10.1, ITEM 9.2**

**ELEVATION**

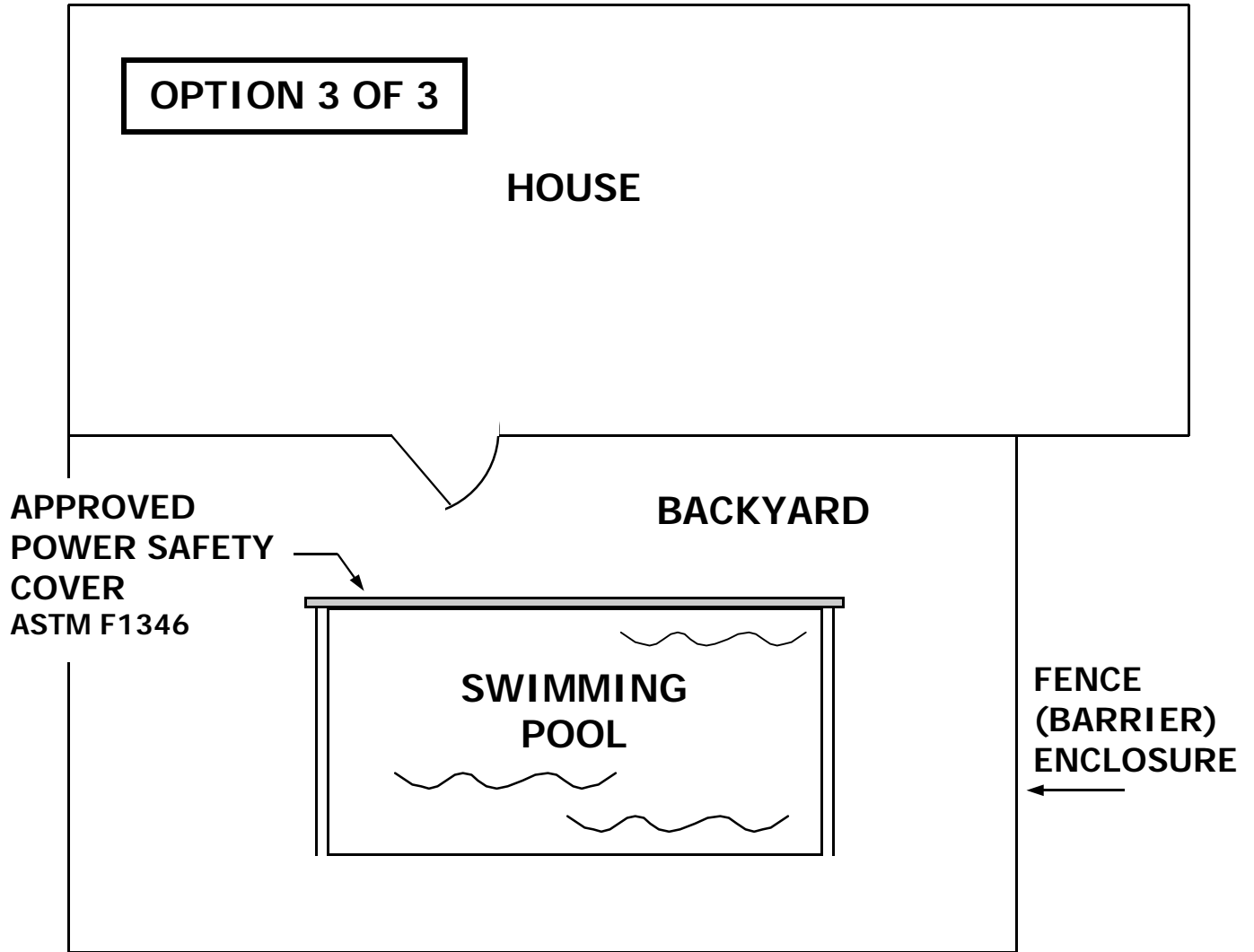

**SECTION 421.10.1, ITEM 9.3**

**SITE PLAN**

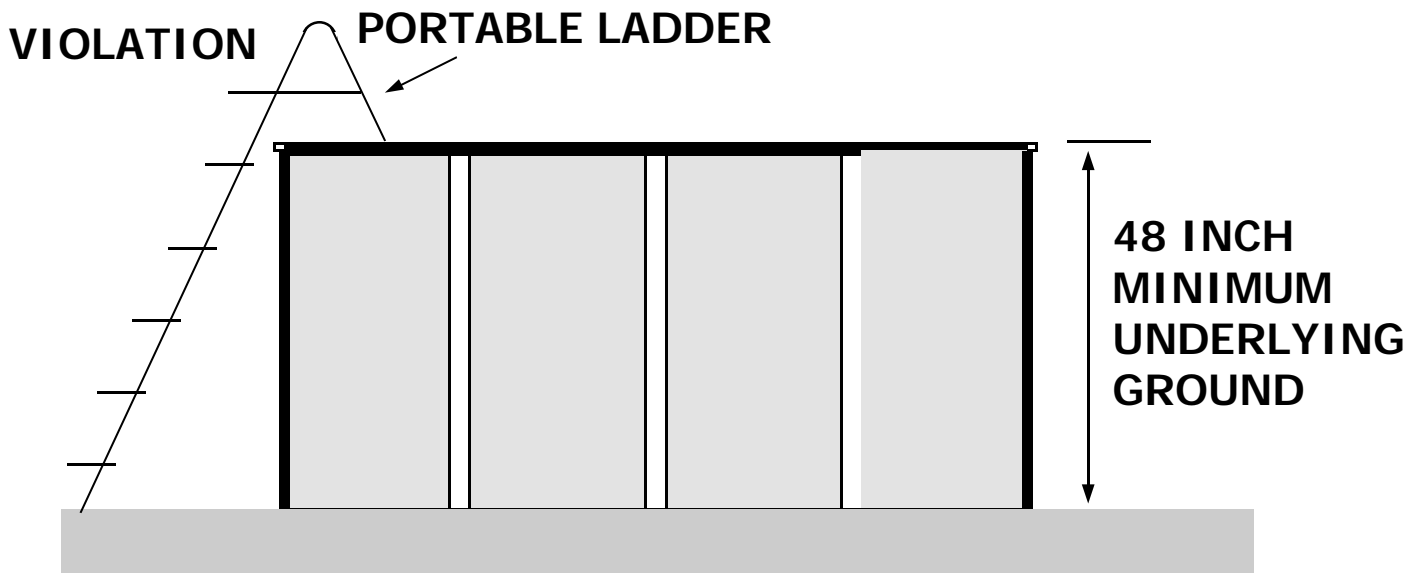

**ABOVE GROUND POOL**

**ELEVATION**

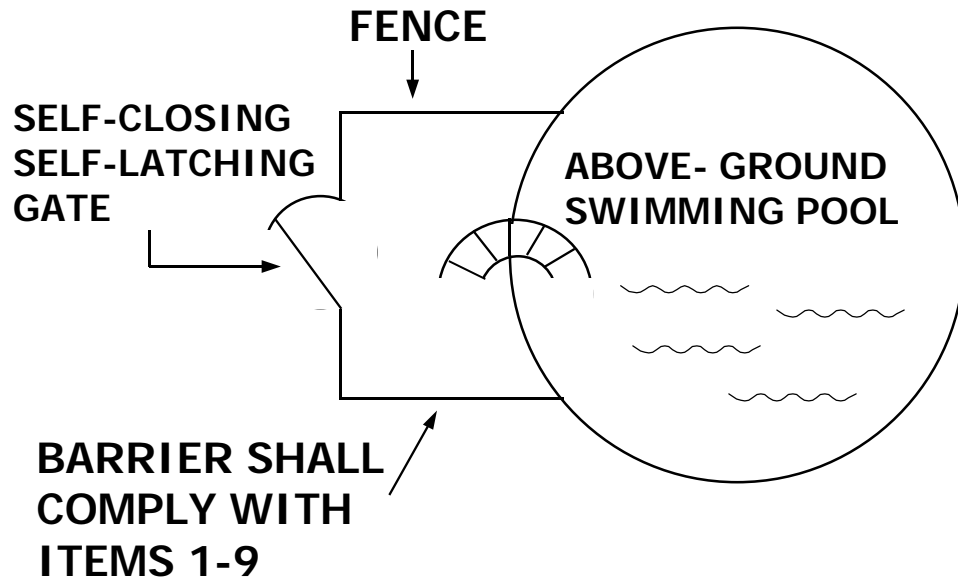

**SECTION 421.10.1, ITEM 10**

**SITE PLAN**



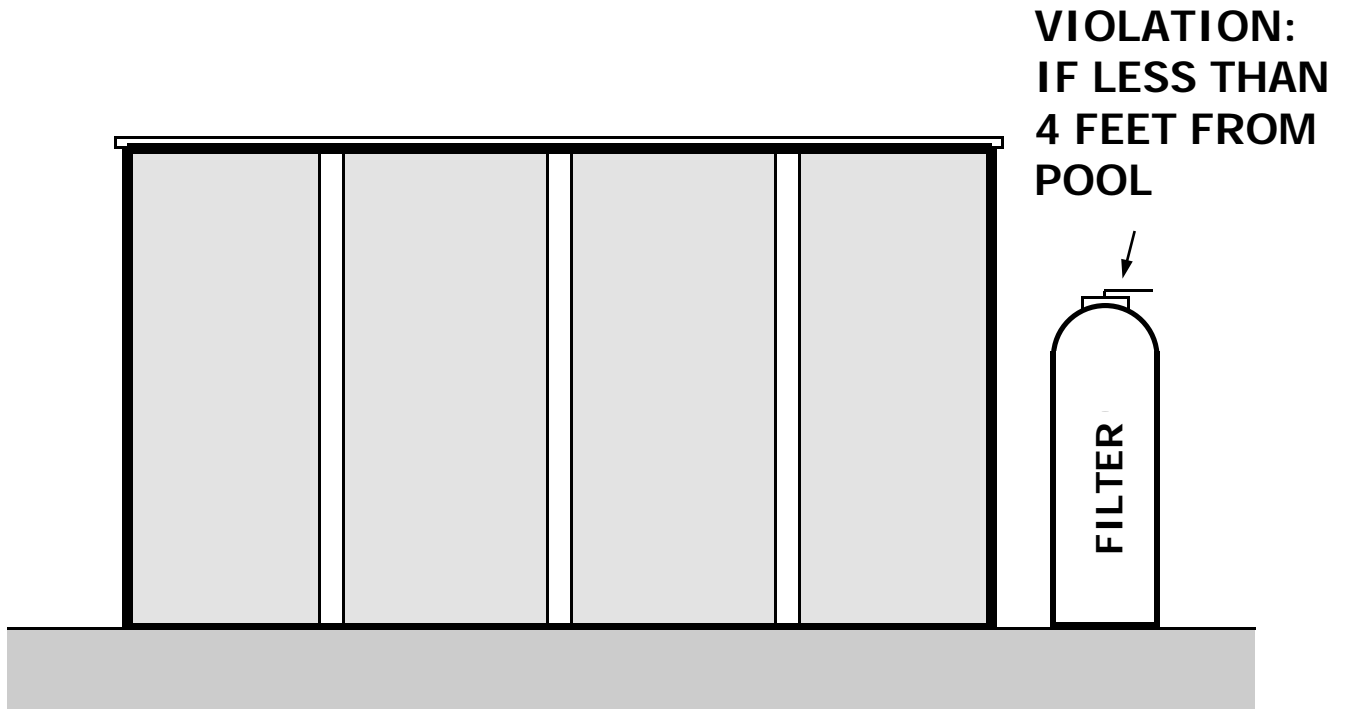

**ABOVE GROUND POOL**

**"PROHIBITED LOCATION"**

**SECTION 421.10.3**

**ELEVATION**

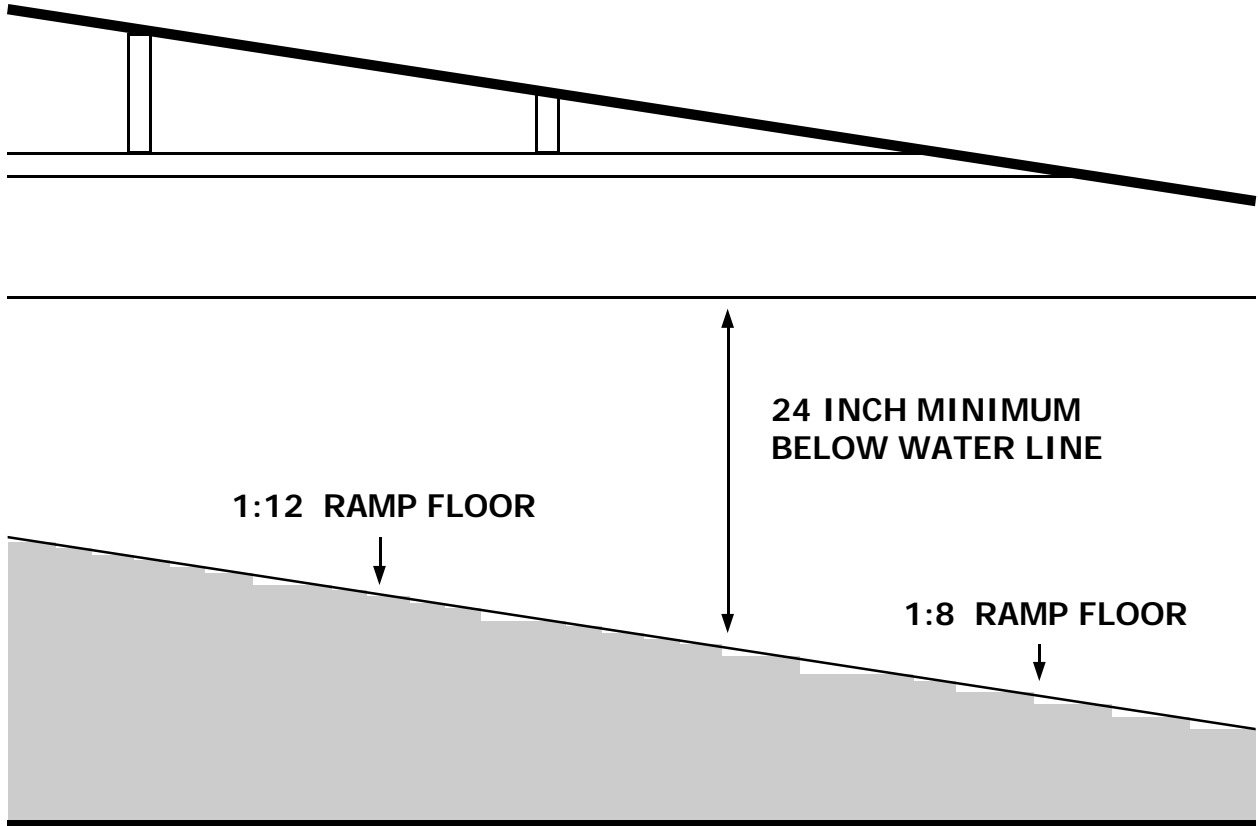

LESS THAN 50 METERS:	RAMPS OR FIXED OR PORTABLE LIFTING EQUIPMENT
50 METERS OR MORE:	RAMPS ONLY. HANDRAILS ON BOTH SIDES OF RAMP

**SECTION 421.10.1 ACCESSIBILITY**

**CROSS SECTION**